

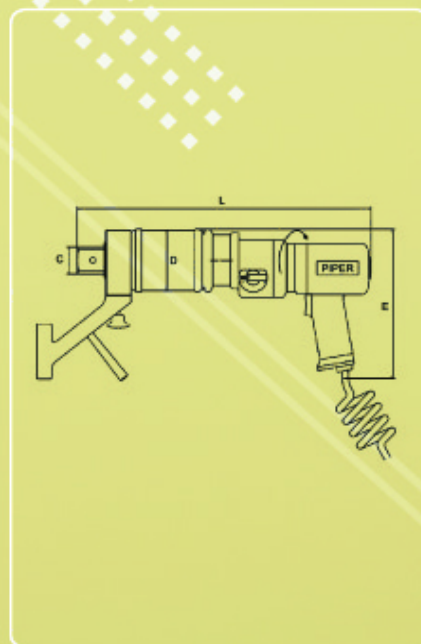

Product Introduction:

- 6bar compressed air,600L/min gas consumption.
- Powerful and low noise, the maximum noise is less 80dBA.
- Through the air pressure adjusting the torque,accuracy $\pm 5\%$, convenient,good repeatability.
- high/low speed switching, improve work efficiency
- Compact planets structure, Small volume, high torque/weight ratio.
- 4 power control, bigger torque span
- 7 – vane pneumatic motor, high efficiency, no impact torque.
- provide greater torque when reverse , satisfy the requirements of bolts removing.
- One–handed operation of positive &negative button,,touch switch valve.
- Industrial design, continuous use ability.



产品简介:

- 6bar压缩空气，最大功率下耗气量600L/min。
- 功率强大而噪音极低，最大噪音值小于80dBA。
- 通过气源处理器调节压力实现控矩，精度达 $\pm 5\%$ ，方便，重复性好。
- 高/低速机械换档，适应不同工况需求。
- 紧凑行星设计，重量轻，扭矩更大。
- 4位式功率管理控制，扭矩跨度更大。
- 7-叶片式高性能气动马达，效率高，使扳手可持续输出无冲击扭矩。
- 反向偏压马达设计提供反转模式的最大功率和扭矩，符合螺栓拆卸时更大扭矩要求。
- 单手操作的正/反转按钮，触摸式开关阀。
- 杰出的连续运行性能，满足高负荷工作。

技术参数

型号	最小扭矩 (Nm)	最大扭矩 (Nm)	方驱C	外径D (mm)	长度L (mm)	宽度E (mm)	重量 (kg)
QDZ08	135	860	1"	88	365	186	5.8
QDZ13	210	1350	1"	88	365	186	5.9
QDZ18	285	1800	1"	88	365	186	6.0
QDZ32	510	3250	1-1/2"	88	422	186	8.3
QDZ36	560	3600	1-1/2"	88	422	186	8.4
QDZ45	720	4590	1-1/2"	88	422	186	8.5
QDZ62	970	6200	1-1/2"	129	451	186	15.2
QDZ108	1690	10800	1-1/2"	129	484	186	17.4



Product Introduction:

- Compared with direct handle wrench, bending helve wrench more suitable restricted space, precision of $\pm 5\%$.
- Equipped with brake system, greatly enhance the convenience and security.
- 6bar compressed air, 600L/min gas consumption.
- Powerful and low noise, the maximum noise is less 80dBA.
- Through the air pressure adjusting the torque, accuracy $\pm 5\%$, convenient, good repeatability.
- High/low speed switching, improve work efficiency.
- Strong reaction arm, Can be 360 degrees adjustment.
- Ergonomic hand grips, buffer rubber reduced by 50% vibration, free rotation.
- Industrial design, continuous use ability.

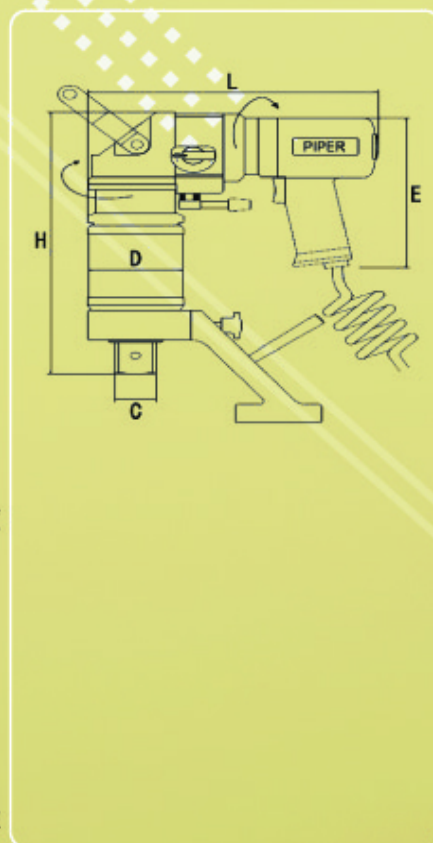

产品简介:

- 与直柄扳手相比,弯柄系列扳手更适应空间受限的场合,采用静音马达,精度达 $\pm 5\%$ 。
- 配备刹车止转系统,保护操作者。
- 6bar压缩空气,最大功率下耗气量600L/min。
- 功率强大而噪音极低,最大噪音值小于80dBA。
- 通过气源处理器调节压力实现控矩,精度达 $\pm 5\%$,方便,重复性好。
- 高/低速机械换挡,适应不同工况需求。
- 高强度整体反作用力臂,不易断裂,可360度调节。
- 新型人机工程学设计把手,与驱动部件自由连接,可旋转,提高操作方便性和舒适性。
- 杰出的连续运行性能,满足高负荷作业。

技术参数

型号	最小扭矩 (Nm)	最大扭矩 (Nm)	方驱C	外径D (mm)	长度L (mm)	宽度E (mm)	高度H (mm)	重量 (kg)
QDW08	135	860	1"	88	259	186	252	7.0
QDW13	210	1350	1"	88	259	186	252	7.1
QDW18	285	1800	1"	88	259	186	252	7.2
QDW32	510	3250	1-1/2"	88	259	186	316	9.5
QDW36	560	3600	1-1/2"	88	259	186	316	9.6
QDW45	720	4590	1-1/2"	88	259	186	316	9.7
QDW62	970	6200	1-1/2"	129	259	186	345	16.4
QDW108	1690	10800	1-1/2"	129	259	186	378	18.6